

# Nomad

# SERVICE BULLETIN

## NEW AIRSPEED LABEL (MODIFICATION N435)

### 1. PLANNING INFORMATION

#### A. Effectivity

##### (1) Aircraft Affected

- (a) All Nomad N24A Series aircraft whose log books do not already record the embodiment of Mod N435 or compliance with Service Bulletin NMD-11-2.
- (b) Pre certification implementation of the intent of this service bulletin is recorded in the Airframe Log Book as Mod N435.

##### (2) Spares Affected

None.

#### B. Reason

The Va Design Manoeuvre Speed is incorrectly stated on the, label adjacent to the Airspeed Indicator. The correct  $V_A$  Design Manoeuvre Speed is 136 kt.

#### C. Description

Label PN 1/N-80-309 is removed and replaced by label PN I/N-80-538.

#### D. Compliance

Within 100 hours Time in Service following receipt of this service bulletin.

#### E. Approval

The modification detailed herein has been approved pursuant to Air Navigation Regulation 40 and conforms with the type certification requirements.

#### F. Manpower

One man 15 minutes.

#### G. Material, Price and Availability

The part required to incorporate the modification detailed in this service bulletin is available free of charge from the operator's local distributor. Distributors are to place a 'No Charge' Purchase Order on GAF through the normal procurement procedure. Purchase orders are to quote the aircraft serial number and Service Bulletin NMD-11-2. This part will be available ex factory from August 1981.

#### H. Tooling, Price and Availability

None required.

Page No	1	2	3
Rev No	0	0	0

# Nomad

## SERVICE BULLETIN

### I. **Weight and Balance**

No change.

### J. **References**

None.

### K. **Publications Affected**

Maintenance Manual  
Illustrated Parts Catalogue.

## 2. **ACCOMPLISHMENT INSTRUCTIONS**

- A. Remove label PN 1/N-80-309 from the LH. Instrument Panel (Ref Figure 1, Detail A).
- B. Clean any residual adhesive from the LH. Instrument Panel by rubbing with a cloth dampened with methylated spirit (methanol).
- C. Attach adhesive label PN 1N-80-538 to the LH. Instrument Panel (Ref Figure 1, Detail B).

### **NOTE**

Prior to receipt of Label PN 1/N-80-538, operators may locally manufacture a temporary label in accordance with Figure 1, Detail B.

## 3. **MATERIALS INFORMATION**

### A. **Parts Required per Aircraft**

New Part No	Qty	Description
1/N-80-538	1	Label

### B. **Parts modified and re identified by the operator**

None.

### C. **Parts Required to Modify Spares**

None.

### D. **Removed Parts**

New Part No	Qty	Description	Instruction/Disposition
1/N-80-309	1	Label	Scrap

### E. **Special Tools and Equipment Required**

None.

# Nomad

## SERVICE BULLETIN

### 4. RECORDING ACTION

Record compliance with Service Bulletin NMD-11-2 in the Airframe Log Book.

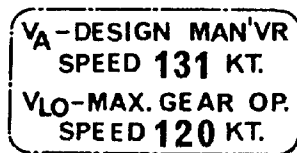
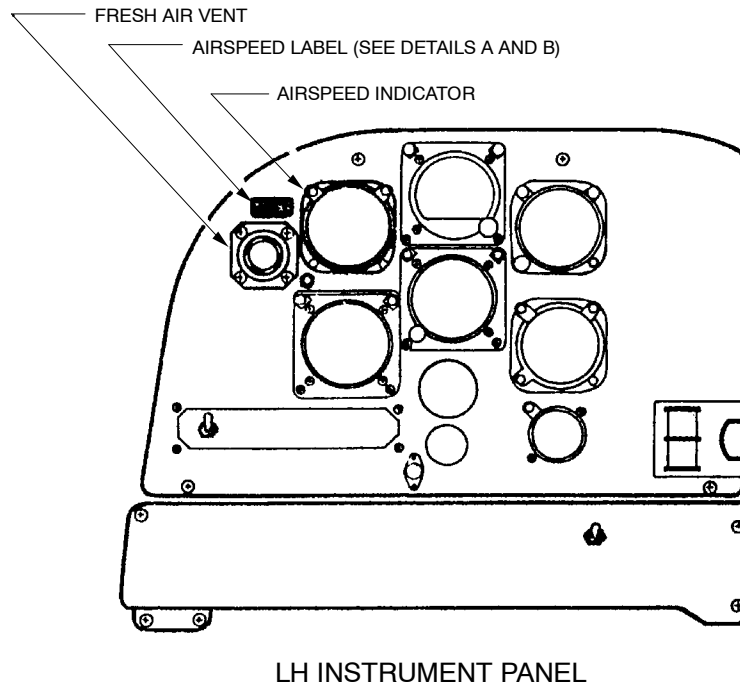

DETAIL A  
(PRE-MOD N435)

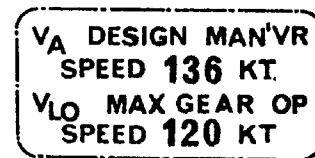

DETAIL B  
(POST MOD N435)

Figure 1 Location Of Airspeed Label