

PO Box 881, Morwell, Victoria 3840, Australia
Ph + 61 (0) 3 5172 1200
Fax + 61 (0) 3 5172 1201
www.gippsaero.com

Service Bulletin

Subject:

Solenoid box breaker modification

Applicability:

All GA8 serial numbers up to S/N GA8-06-098

Amendments:

Nil – Initial issue

Background:

The 1A underfloor circuit breakers have been observed on some aircraft operating in high ambient temperatures to trip under normal load conditions. This Service Bulletin modifies the solenoid box by changing the type of 1A breakers fitted.

Compliance:

Optional, but recommended incorporation at owner's discretion.

Weight and Balance:

Negligible effect on weight and balance.

Approval:

The technical aspects of this Service Bulletin have been approved under a CASA Authorisation.

Parts:

Item	Part Number	Description	Qty
1	Texas Instruments Klixon 2TC2-1	Circuit Breaker, 1A	3

Parts Availability:

Parts can be obtained directly from Gippsland Aeronautics.

Tel.: +61 03 5172 1200

Fax.: +61 03 5172 1201

Email: spares@gippsaero.com

Labour:

Three hours should be allocated for completing the work detailed in this Service Bulletin.

Warranty:

Gippsland Aeronautics factory participation is limited to aircraft in warranty at the time of compliance. For details relating to claims contact Gippsland Aeronautics.

Instructions:**WARNING:**

THE CAPACITOR CONTAINED WITHIN THE SOLENOID BOX IS A POTENTIAL HAZARD TO PERSONNEL MAINTAINING THE AIRCRAFT BY VIRTUE OF THE POTENTIAL FOR INADVERTENT SHORTING OF THE POSITIVE SIDE TO GROUND. THIS WOULD CAUSE A SIGNIFICANT ARC, WHICH, IF IT CAME INTO CONTACT WITH ANY PART OF THE BODY, COULD RESULT IN A MINOR BURN OR CAUSE A REFLEX ACTION THAT MAY SHORT OUT OTHER ELECTRICAL CONNECTIONS.

BEFORE REMOVING THE COVER PANEL TO ACCESS THE UNDERFLOOR AREA IN FRONT OF THE PILOT'S SEAT, PERFORM THE FOLLOWING ACTION TO ENSURE THAT THE CAPACITOR CIRCUIT IS DISARMED:

- (I) PULL THE 1 A BUS 2 CONTROL BREAKER
- (II) SWITCH THE BUS 2 MASTER SWITCH ON

ENSURE THAT THE BREAKER REMAINS OPEN AND THE MASTER SWITCH REMAINS ON FOR THE DURATION THAT THE COVER PANEL IS REMOVED. NOTE THAT BUS 2 IS NOT LIVE WHILST THE BUS 2 CONTROL BREAKER IS PULLED.

WARNING:

DO NOT COMMENCE THE INSTRUCTIONS CONTAINED WITHIN THIS SERVICE BULLETIN IN CONJUNCTION WITH MAINTENANCE ON THE FUEL SYSTEM. THE ESCAPE OF FUEL FUMES UNDER THE FLOOR AND/OR IN THE AIRCRAFT MAY CAUSE AN EXPLOSION.

1. Remove the pilot seat and gain access to the solenoid box. Take off the fibre glass battery cover.
2. Gain access to the battery box. Disconnect the positive terminal connected to the battery from the aircraft as a precautionary measure. Refer to the GA8 Service Manual Section Chapter 24.
3. Gain access to the internal components of solenoid box by removal of screws as noted in Figure 1. Take care not to damage the heads of the screws when undoing them. Remove the fibre glass sheet. Refer to the GA8 Service Manual Section Chapter 24 taking specific note of the warning in Section 24-00-00.

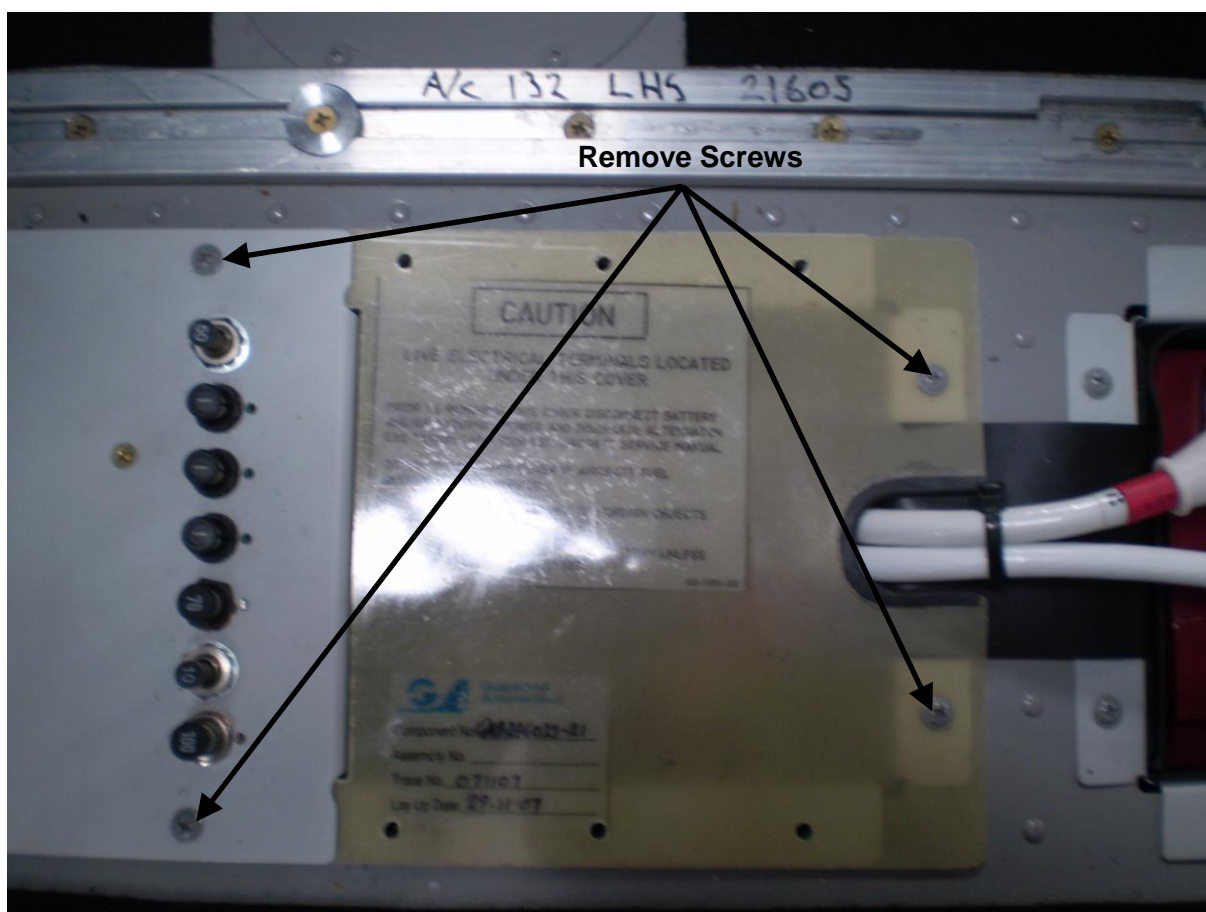

Figure 1 - Screws to be removed to gain access to internal assembly of the solenoid box

- Gain access to the Circuit Breaker Assembly and remove this from the main solenoid box assembly. This will require disconnecting of wires PB4A8, PB4B8, PB2A6, PB2B6 to ease the modification of the circuit breaker panel. Refer to Figure 2. Remove the existing 1A breakers from the assembly and discard. Retain the bus bar (GA8-311022-33) for reinstallation.

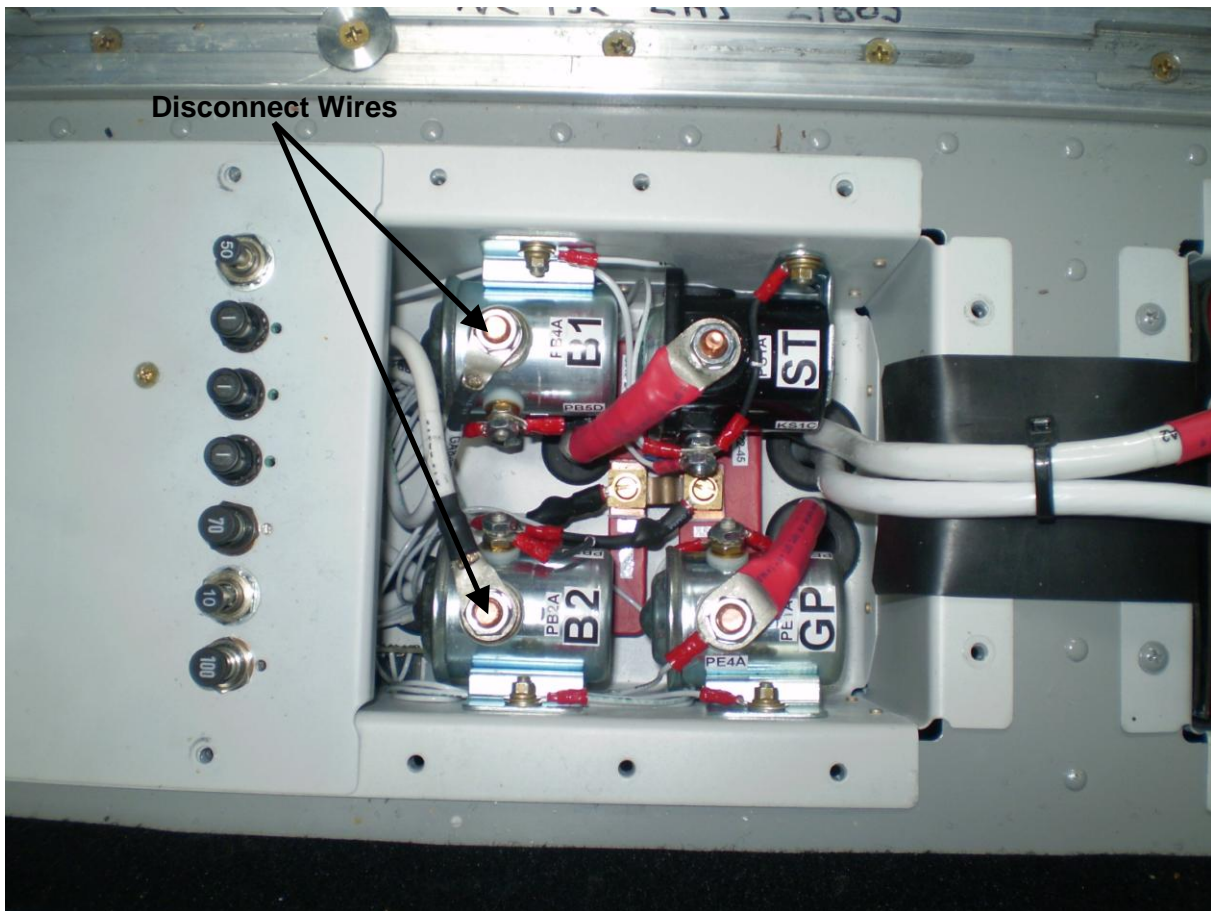

Figure 2 - Showing the first two wires to be disconnected

5. Modify the Breaker Panel as detailed in Figure 3. Each new breaker requires the existing mounting hole to be enlarged to 0.4375 inches diameter and the addition of a 0.125 inch diameter hole per location. Remove all swarf.

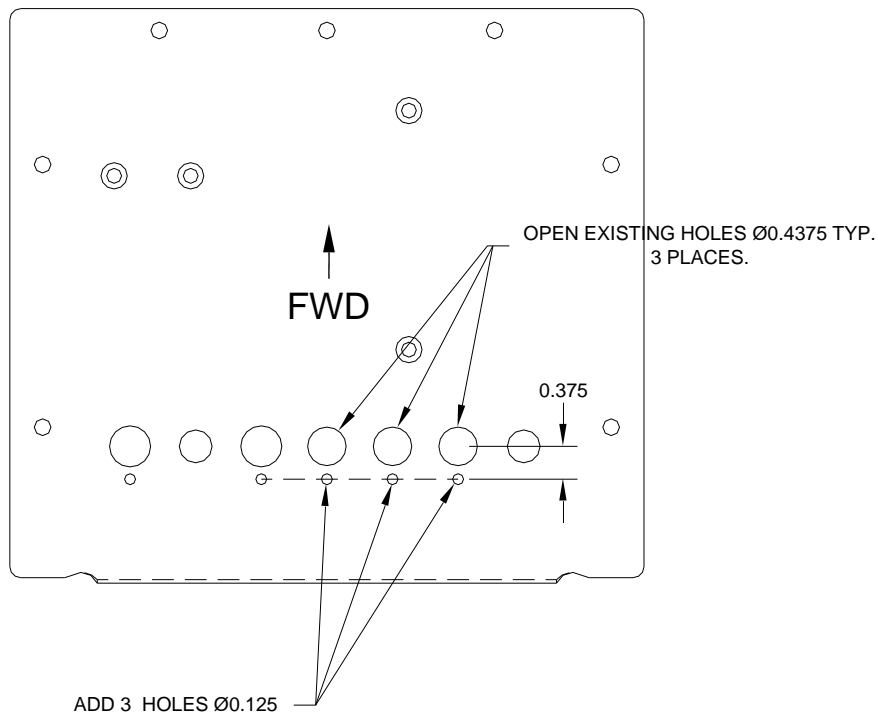

Figure 3 - Modification to Breaker Panel, viewed from above when fitted into aircraft

6. Replace the 1A circuit breakers with 2TC2-1 breakers. Reinstall Bus Bar. Refer to Figure 4.



Figure 4 - Modified Breaker Assembly

- Refit the Circuit Breaker Assembly to the solenoid box. Refer to Figure 5 for the wiring to circuit breakers. Refer also to Chapter 24, Figure 24-1 of the Service Manual

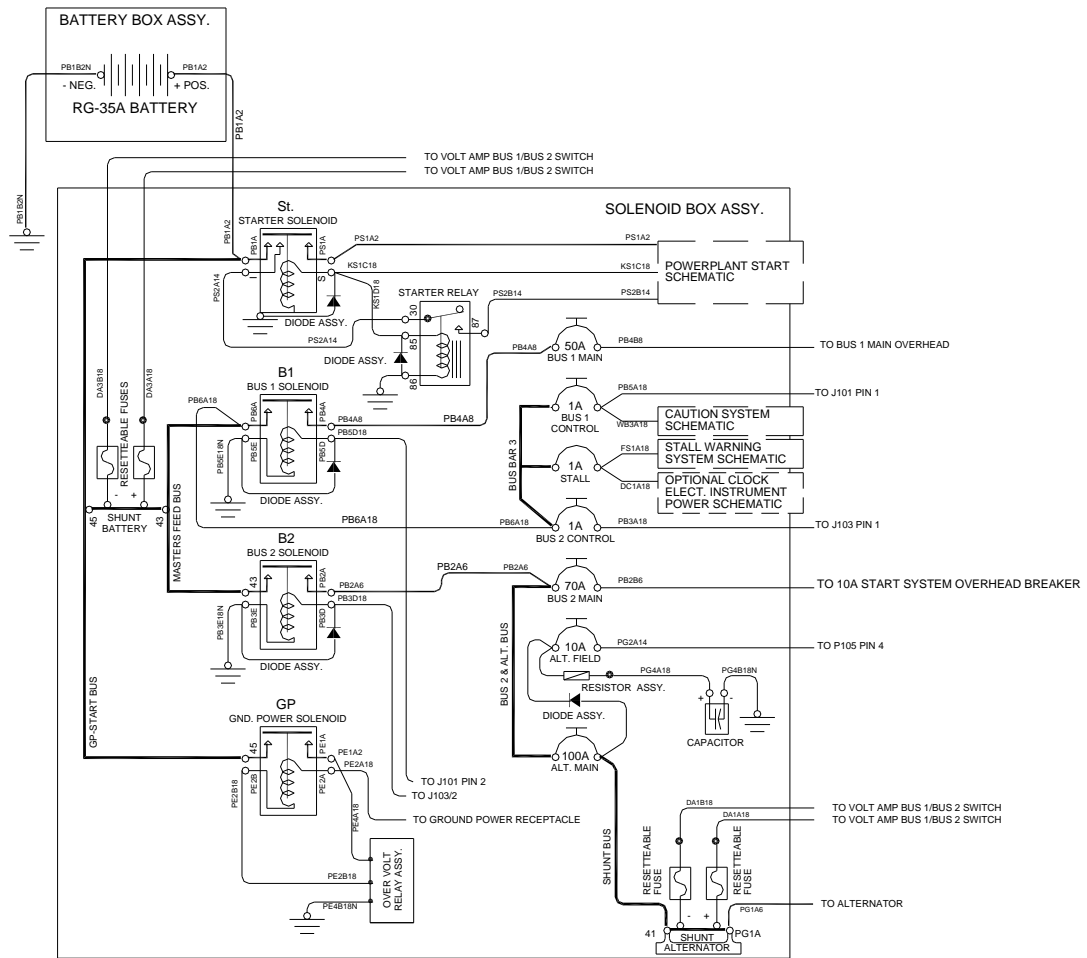

Figure 5 - Partial wiring schematic showing underfloor circuit breakers.

- Refit the solenoid box with fibre glass cover into the aircraft using the original fasteners. Reconnect the battery to the aircraft electrical system
- Reinstall the fibreglass battery cover using the original fasteners.
- Reinstall the Pilot Seat.

Documentation:

Update aircraft log book to reflect incorporation of this Service Bulletin.

Compliance Notice:

Complete the Document Compliance Notice and return to Gippsland Aeronautics by fax or mail.

DOCUMENT COMPLIANCE NOTICE



Document: Service Bulletin SB-GA8-2008-50

Issue 1

Aircraft Serial Number: GA8-_____

Service Bulletin SB-GA8-2008-50 Issue 1 has been incorporated in the above aircraft.

Date: _____

Signed

On behalf of (*company name*): _____

Please post fax or email this compliance notice to:

Gippsland Aeronautics
Attn: Technical Services
P.O. Box 881
Morwell Victoria 3840
Australia
Fax.: +61 03 5172 1201
Email: techrec@gippsaero.com