

Nomad

SERVICE BULLETIN

ENGINE NACELLE — EARTH POSITION RELOCATION (MOD N890)

1. PLANNING INFORMATION

A. Effectivity

(1) Aircraft affected:

(a) **N22 Series** line sequence numbers 1 to 9, 11 to 29, 31, 33, 35, 37, 39 to 41, 43, 45, 47 to 59, 61, 63, 65 to 70, 82 to 88, 90 to 95, 97, 100, 102 to 114, 116, 118, 125, 126, 131 to 134, 137, 138, 141, 143 to 170.

(b) **N24 Series** line sequence numbers 10, 30, 32, 34, 36, 38, 42, 44, 46, 60, 62, 64, 71 to 81, 89, 96, 98, 99, 101, 115, 117, 119 to 124, 127 to 130, 135, 136, 139, 140, 142.

(2) Spares affected:

None

B. Reason

To provide improved earthing arrangements for the Fire Detector Switches and, if fitted, Propeller Autofeather Torque Pressure Switches.

C. Description

Earth wires from the fire detector switches (and, if fitted, Propeller Autofeather Torque Pressure Switches) are attached at a new location on the lower engine yoke.

D. Compliance

(1) The compliance requirements of this Service Bulletin are mandatory.

(2) To be carried out at the next 300 hours inspection, following receipt of this Service Bulletin.

E. Approval

The requirement detailed herein has been approved by a person authorised under Civil Aviation Regulation 35 and conforms to the type certification requirements.

F. Manpower

8 Hours

G. Materials, Price and Availability

To be sourced locally.

Page No	1	2	3	4	5	6	7	8
Rev No	0	0	0	0	0	0	0	0

Nomad

SERVICE BULLETIN

H. Tooling, Price and Availability

None required.

I. Weight and Balance

Negligible effect on weight and balance.

J. References

Maintenance Manual	Chap 26
Wiring Diagram Manual	Chap 26
CO G214 or G214-24	Maintenance Practices, WDM

K. Publications Affected

Maintenance Manual
Wiring Diagram Manual

2. ACCOMPLISHMENT INSTRUCTIONS - Applicable to both engine nacelles

A. Part 1 - Basic aircraft (including Mod N78) without CO G214 (or G214-24)

WARNING

INCORPORATION OF THESE INSTRUCTIONS REQUIRES WORKING IN THE VICINITY OF THE PROPELLERS. ENSURE THAT THE AIRCRAFT ELECTRICAL POWER SUPPLIES (BATTERY AND/OR EXTERNAL) ARE DISCONNECTED.

- (1) Open Upper Cowl as follows:
 - (a) Pre-Mod N469 - Unlatch the two Airloc quick-release toggle fasteners on each side of the cowl; or
 - (b) Post-Mod N469 - Unlatch the Camloc and the two Airloc quick-release toggle fasteners on each side of the cowl; or
 - (c) Post-Mod N515 - Unlatch the Hartwell catches on each side of cowl; and
 - (d) Lift cowl and apply prop to hold.
- (2) Open Lower Cowl as follows:
 - (a) Pre-Mod N469 - Unlatch the two Airloc quick-release toggle fasteners or
 - (b) Post-Mod N469 - Unlatch the Camloc and the two Airloc quick-release toggle fasteners; or
 - (c) Post-Mod N515 - Unlatch the two Hartwell catches and allow the cowl to swing open.

NOTE

For work on the right-hand engine it is recommended that the wing strut is wrapped with soft cloth to prevent damage.

- (3) Remove Upper Front Fairing (Ref MM Chap 71-10-00, Para 1.E.).

7 Feb 2001

NMD-54-5
Page 2 of 7

Nomad

SERVICE BULLETIN

- (4) Remove Lower Front Fairing (Ref MM Chap 71-10-00, Para 1.G.).
- (5) Locate (Ref Fig 1) and remove Fire Detector Switches from the mounted positions (Ref MM Chap 26-10-00, Para 1.E.). Remove and discard earth wire from each switch.

NOTE

It is only necessary to remove earth wires W3A18N, W4A18N and, if Mod N78 fitted, W81A18N.

- (6) Make up new earth wires with wire MS25038/1-18-9 and lugs MS25036-102 as follows:
 - (a) LH Fire Detector Switch, Ref W151A18N, 90 inches,
 - (b) RH Fire Detector Switch, Ref W152A18N, 30 inches, and
 - (c) Centre Detector Switch (if fitted by Mod N78), Ref W153A18N, 44 inches.
- (7) Attach earth wires to relevant terminals in the Fire Detector Switches. Refit Fire Detector Switches as per MM Chap 26-10-00, Para 1.F.
- (8) Drill a 3.70 mm (0.1457 in) hole at the new earth point on the RH side of the lower mounting yoke (Ref Fig 2). Prepare the surface as per MM Chap 20-20-00.
- (9) Run earth wires to the new earth point. Where possible tie earth wires to existing looms. Attach with screw (MS35206-327), plain steel washer (AN960-6), aluminium washer (AN960-D6) placed as per Figure 2, spring washer (MS35338-41) and self-locking nut (MS21083-N06). Refinish the surface as per MM Chap 20-20-00.
- (10) Carry out a functional test of the Fire Detectors as per MM Chap 26-10-00, Para 2.A.
- (11) Refit Upper and Lower Front Fairings (Ref MM Chap 71-10-00).
- (12) Close and secure Upper and Lower Cowls.

B. Part 2 - Aircraft with CO G214 (or G214-24)

WARNING

INCORPORATION OF THESE INSTRUCTIONS REQUIRES WORKING IN THE VICINITY OF THE PROPELLERS. ENSURE THAT THE AIRCRAFT ELECTRICAL POWER SUPPLIES (BATTERY AND/OR EXTERNAL) ARE DISCONNECTED.

- (1) Carry out the requirements of Para 2.A.(1) to (10).

NOTE

For work on the right-hand engine it is recommended that the wing strut is wrapped with soft cloth to prevent damage.

- (2) Locate Torque Oil Pressure Switch (Ref Fig 3), and remove electrical connector.

Nomad

SERVICE BULLETIN

- (3) Open connector, locate Pin F and disconnect wire K24A18N (or K38A18N) and disconnect from present earth point.
- (4) Make new earth wire using wire MS25038/1-18-9 and lug MS25036-102 of length 50 in. Label as K24A18N.
- (5) Connect to Pin F in connector, reassemble connector and refit to Torque Oil Pressure Switch.
- (6) Run earth wire to the new earth point (Ref Fig 2). Where possible tie earth wire to existing looms. Connect as per Para 2.A.(9).
- (7) Refit Upper and Lower Front Fairings (Ref MM Chap 71-10-00).
- (8) Close and secure Upper and Lower Cowls (Ref MM Chap 71-10-00).
- (9) Carry out Autofeather function test as per Maintenance Practices of CO G214.

3. MATERIALS INFORMATION

A. Parts Required per Aircraft

- (1) For Part 1 and Part 2

New Parts				
Part No	Qty	Description	Old Part No	Instruction/Disposition
MS35206-327	2	Screw		
AN960-6	4	Washer, plain steel		
AN960-D6	2	washer, aluminium		
MS35338-41	2	Washer, spring		
MS21083-N06	2	Nut, self-locking		
M25038/1-18-9	A/R	Wire, HI-TEMP 18g		
MS25036-102	14	Terminal Lug, crimped		
M39029/32-259	2	Socket, contact (Cannon)		

B. Materials Required for Corrosion and Protection Treatments

As required to refinish cleaned surface at engine yoke (Ref MM Chap 20-20-00).

4. SPECIAL TOOLS AND EQUIPMENT

None required

5. RECORDING ACTION

Record compliance with Service Bulletin NMD-54-5 in the Airframe Log Book.

7 Feb 2001

Nomad SERVICE BULLETIN

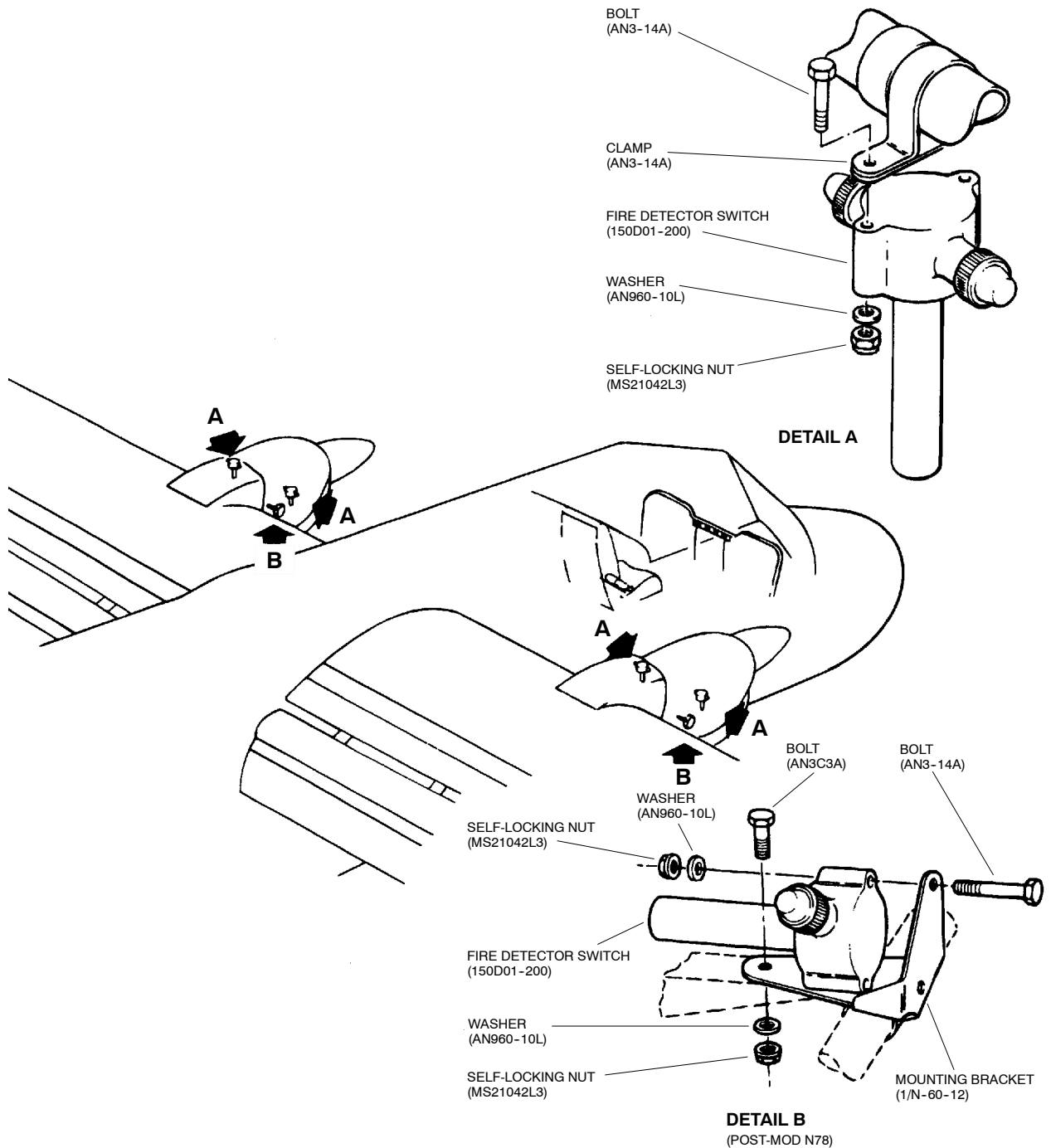

Figure 1 Details of Fire Detector Mountings

7 Feb 2001

Nomad SERVICE BULLETIN

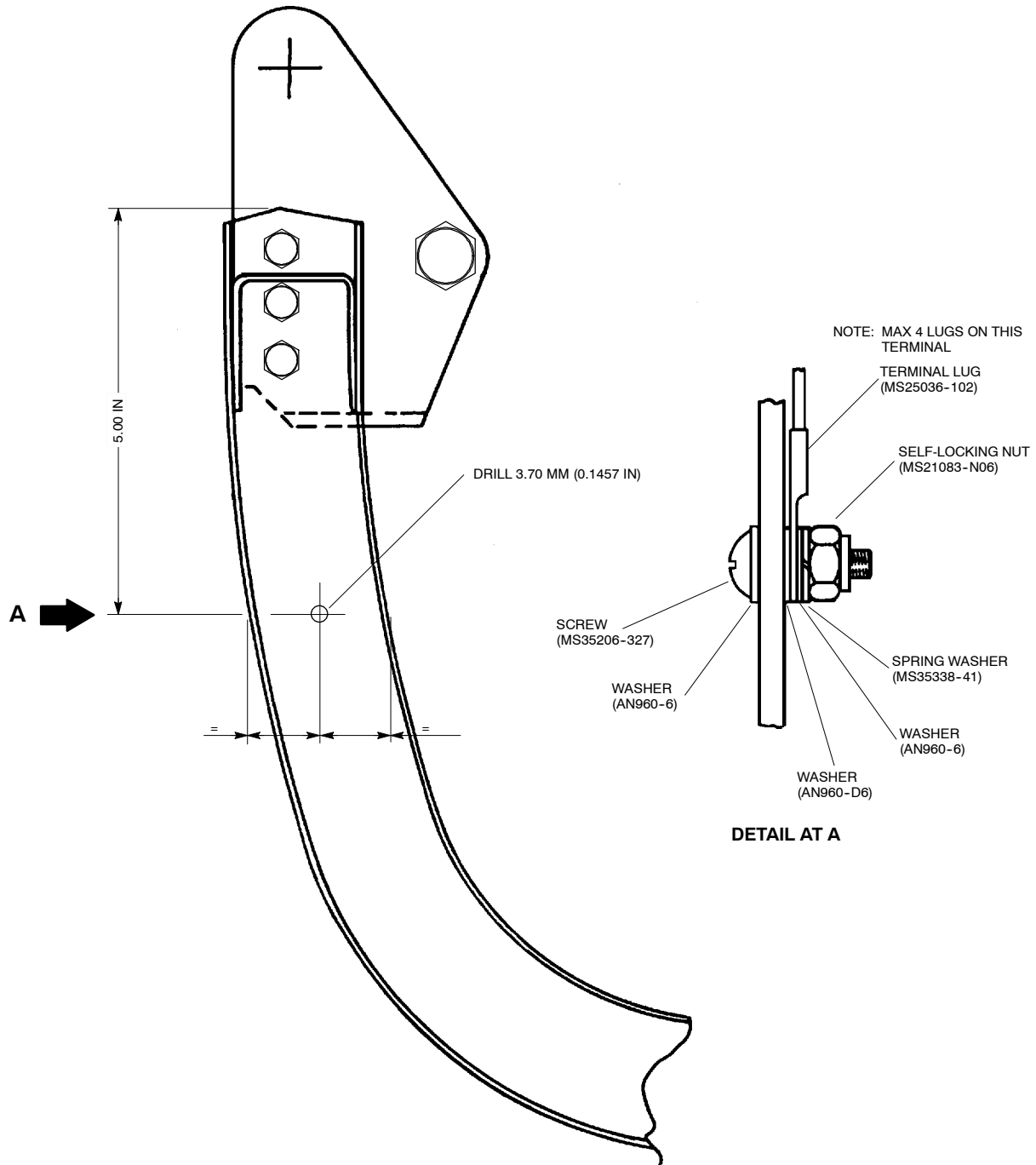

Figure 2 Details of new earth point

7 Feb 2001

Nomad

SERVICE BULLETIN

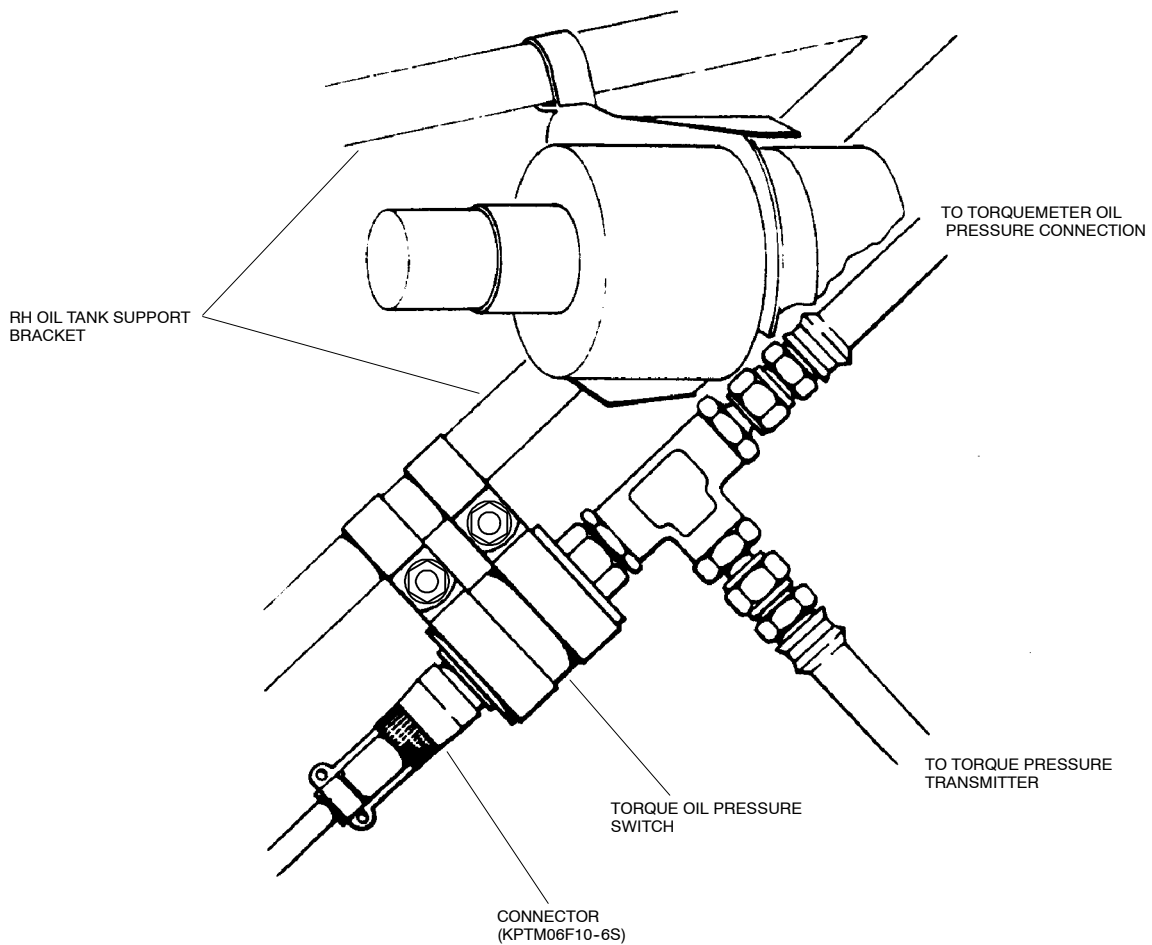

Figure 3 Mounting of Torque Oil Pressure Switch

7 Feb 2001