

Nomad

ALERT SERVICE BULLETIN

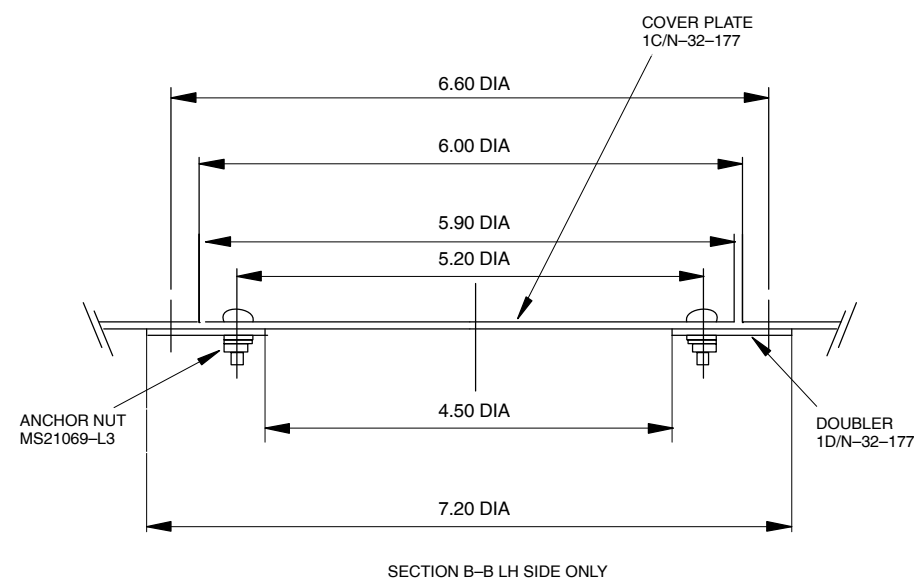

- RIVET CODE**
- 1 MS20470AD4-4
 - 2 MS20470AD3-4
 - 3 MS20426AD3-3
 - 4 MS20426AD3-4
 - 5 MS20426AD4-4
 - 6 MS20470AD4-5
 - 7 MS20600AD4W1
 - 8 MS20426AD4-5
 - 9 MS1097AD3-3 CSK HD

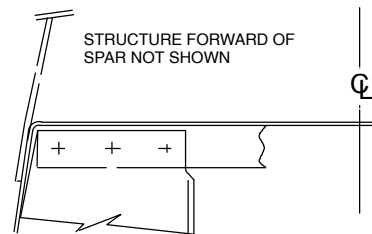
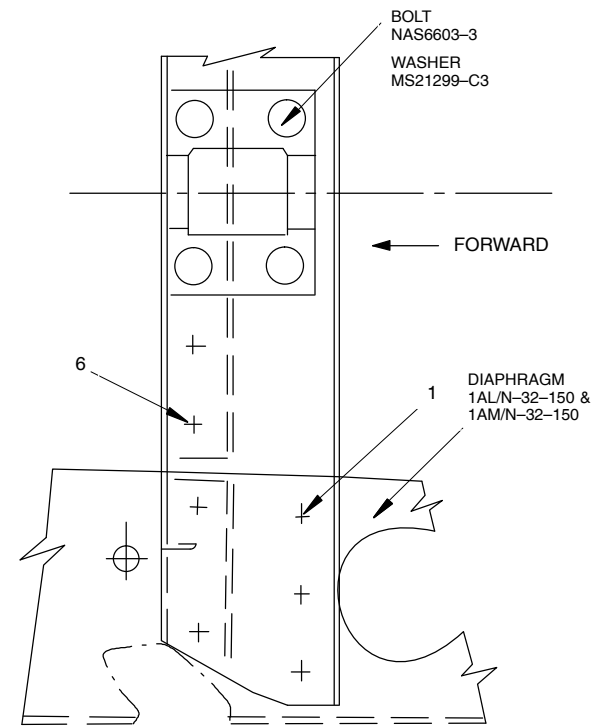

SECTION D-D

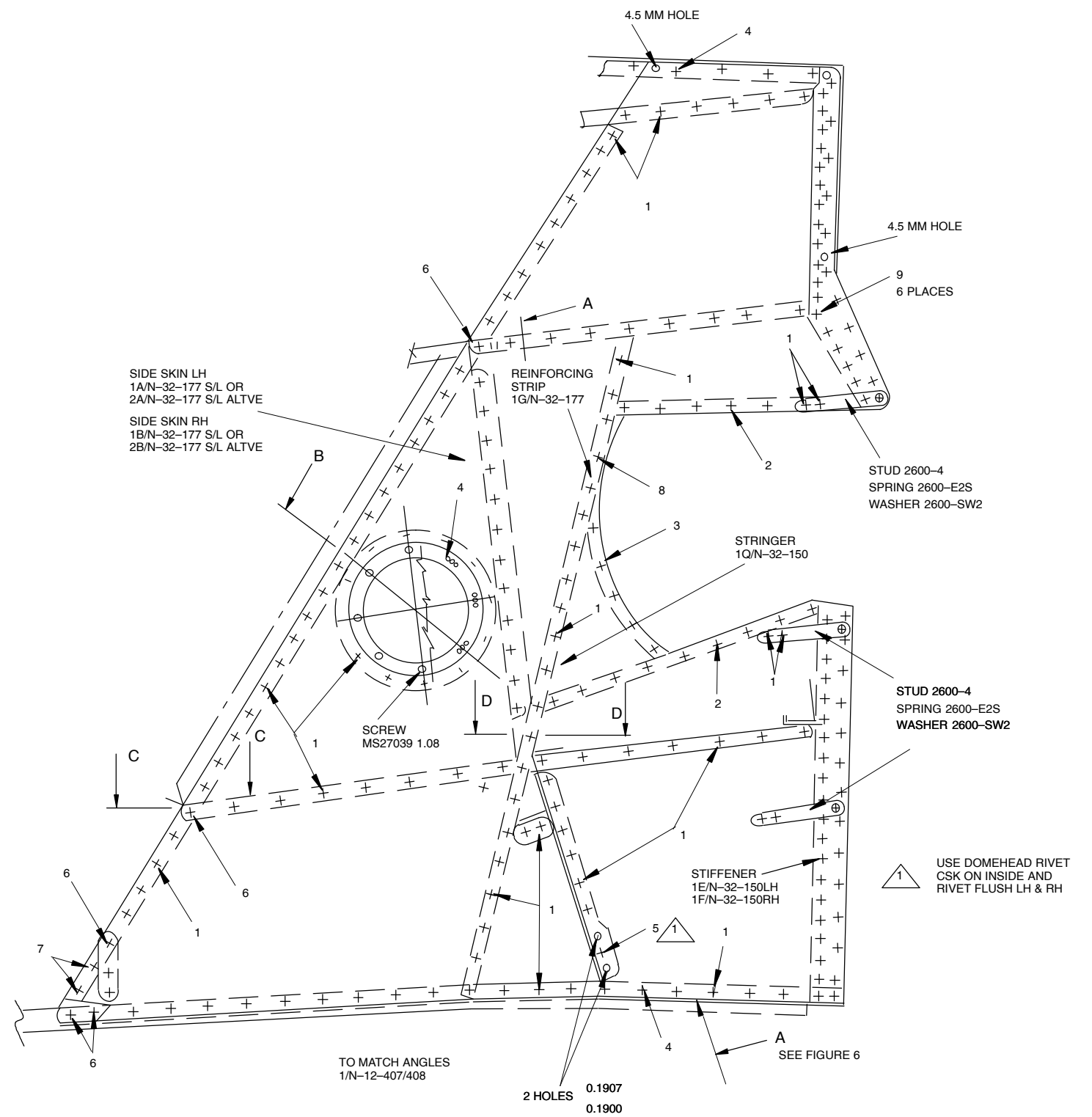

Figure 10 Dorsal Fin Structural Details

Nomad

ALERT SERVICE BULLETIN

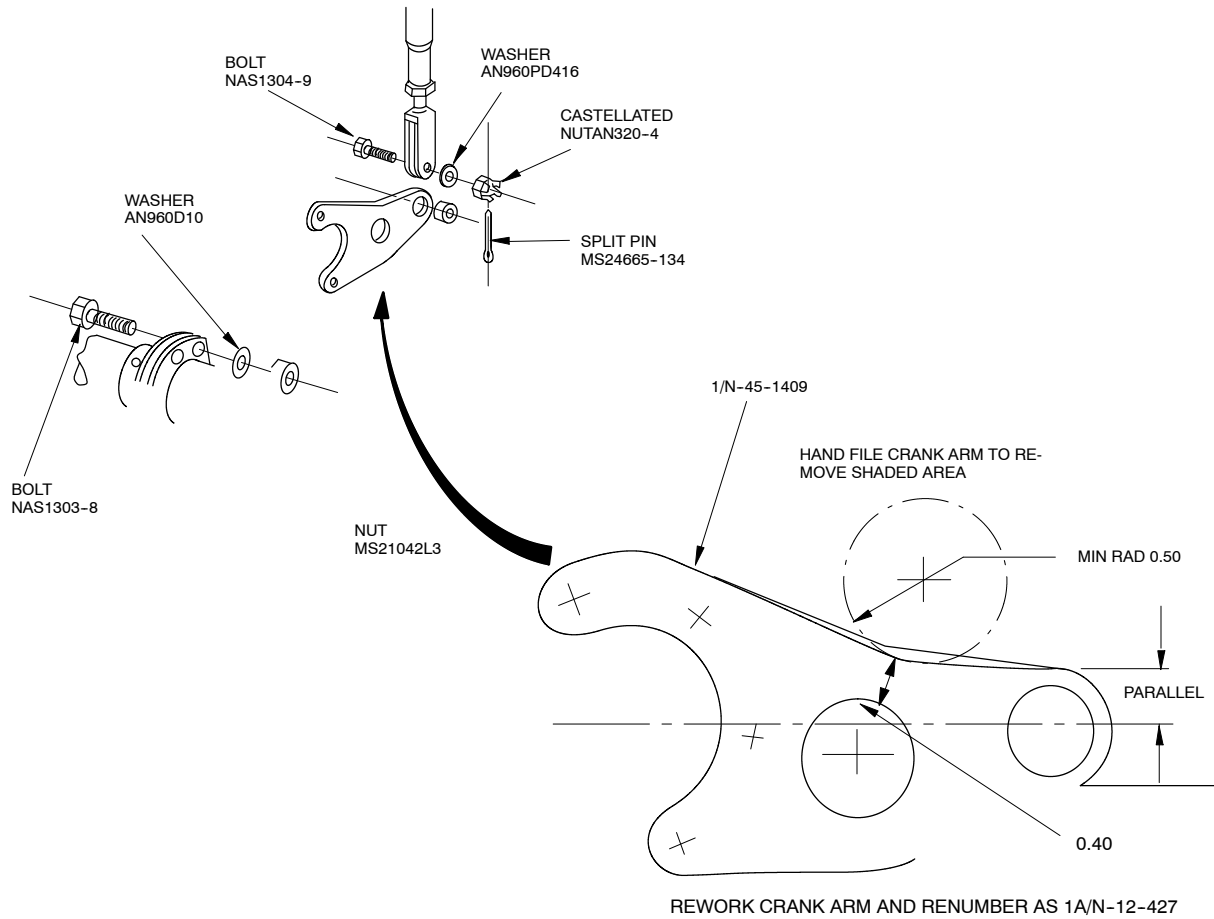

Figure 11 Crank Arm Rework

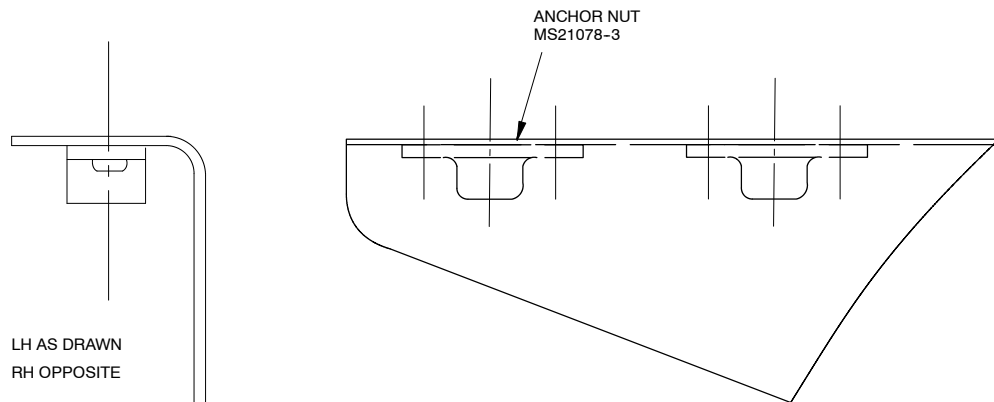

Figure 12 Dummy Attachment Angles

Nomad

ALERT SERVICE BULLETIN

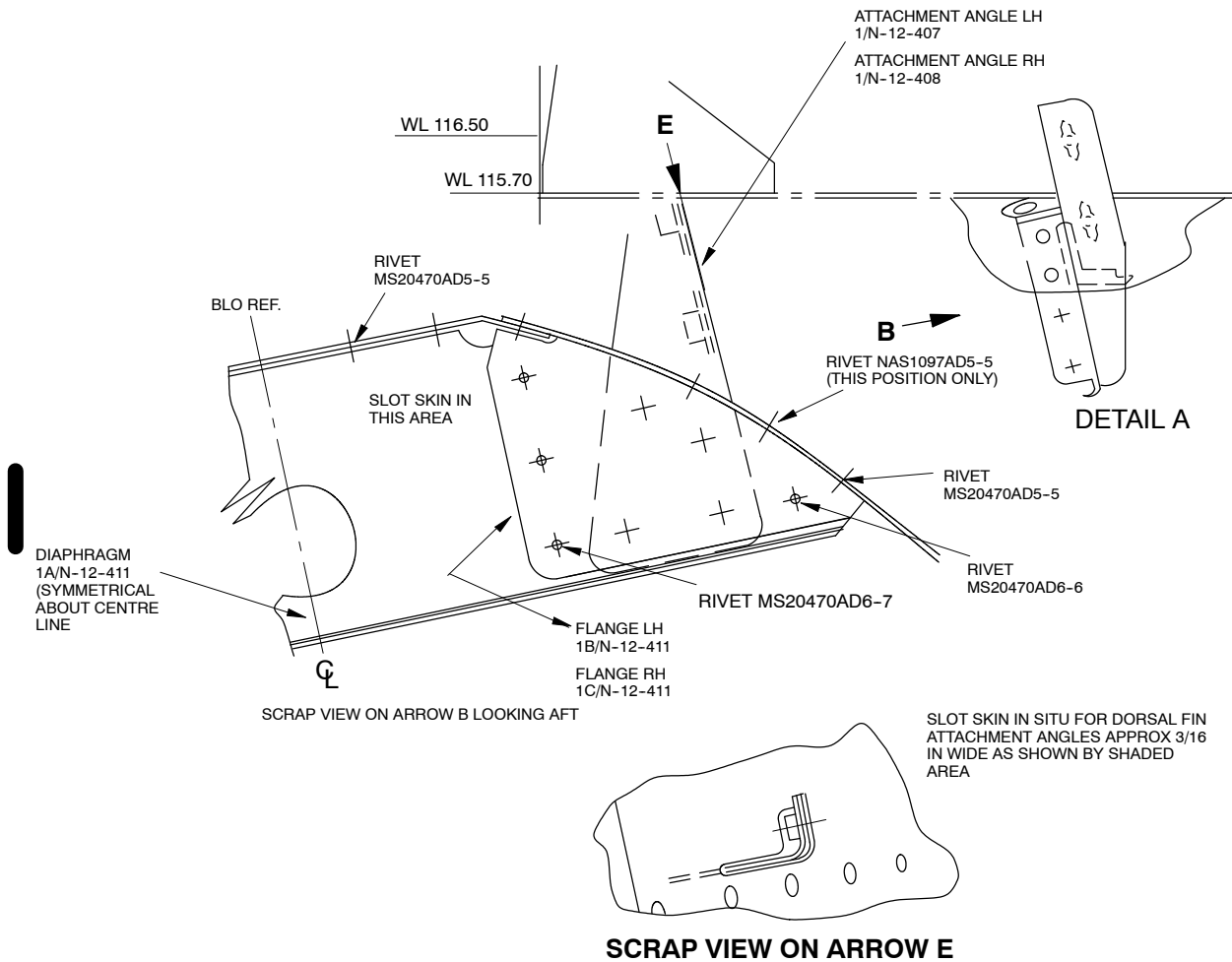

Figure 13 Dummy Attachment Angles — Fitment

15 Mar 90
Rev 6 1 Jun 92

Nomad

ALERT SERVICE BULLETIN

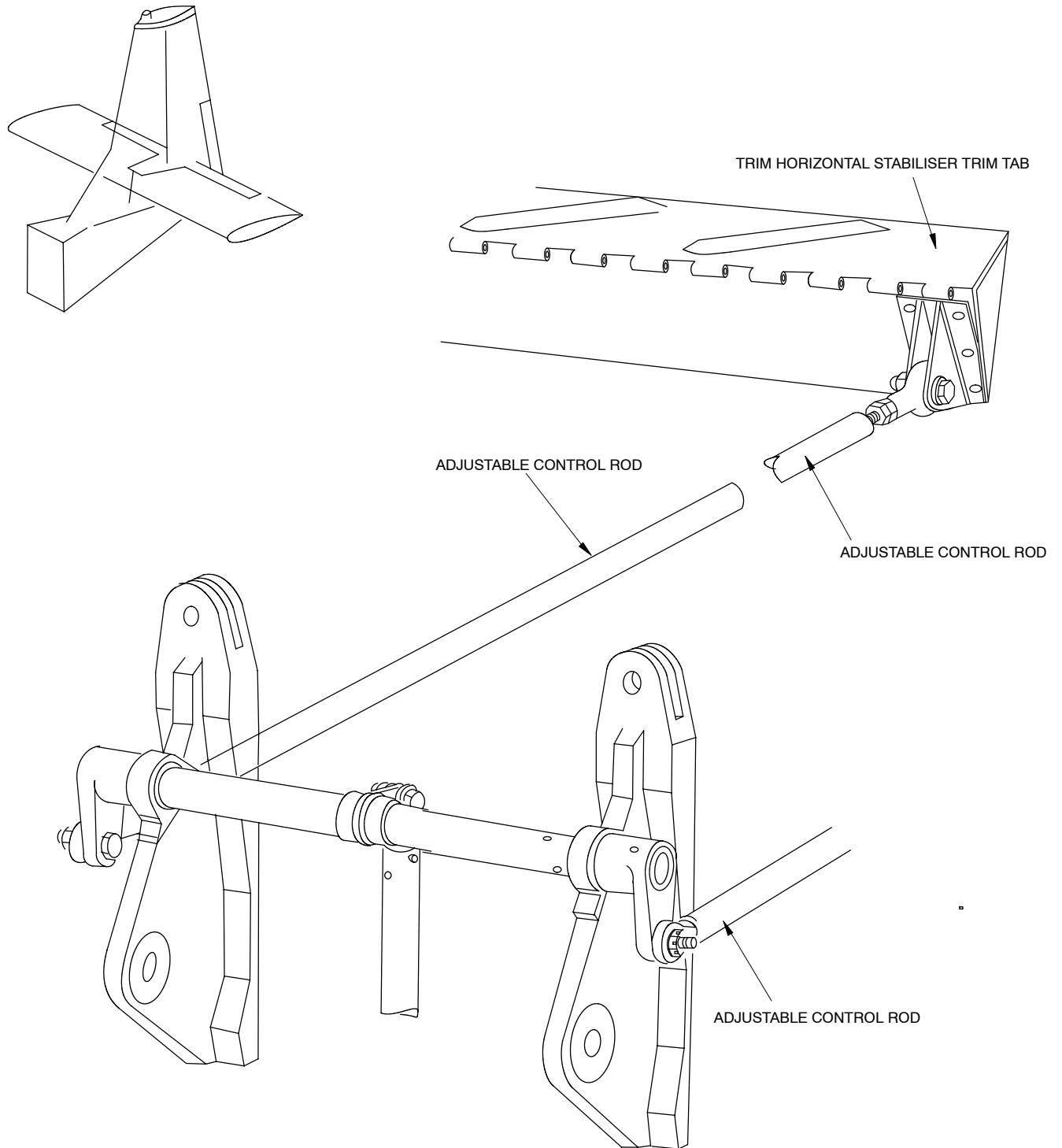

Figure 14 Horizontal Stabiliser Trim Control Rods

15 Mar 90
Rev 6 1 Jun 92

AEROSPACE TECHNOLOGIES OF AUSTRALIA
A.C.N. 008 622 008
A BOEING AUSTRALIA COMPANY

ANMD-55-26

Page 55

Nomad

ALERT SERVICE BULLETIN

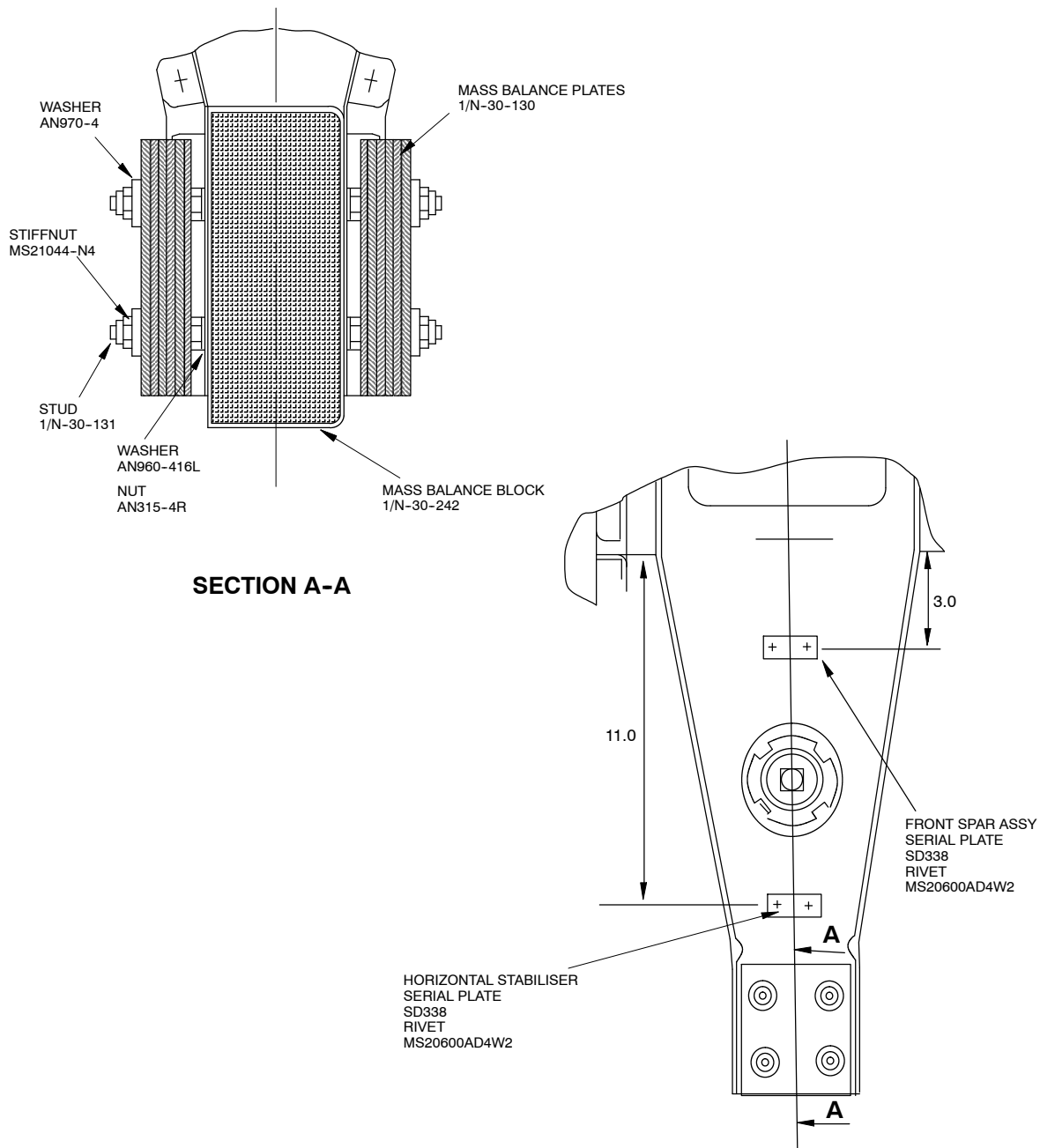

Figure 15 Serial Plate and Mass Balance Plates — Fitting

Nomad

ALERT SERVICE BULLETIN

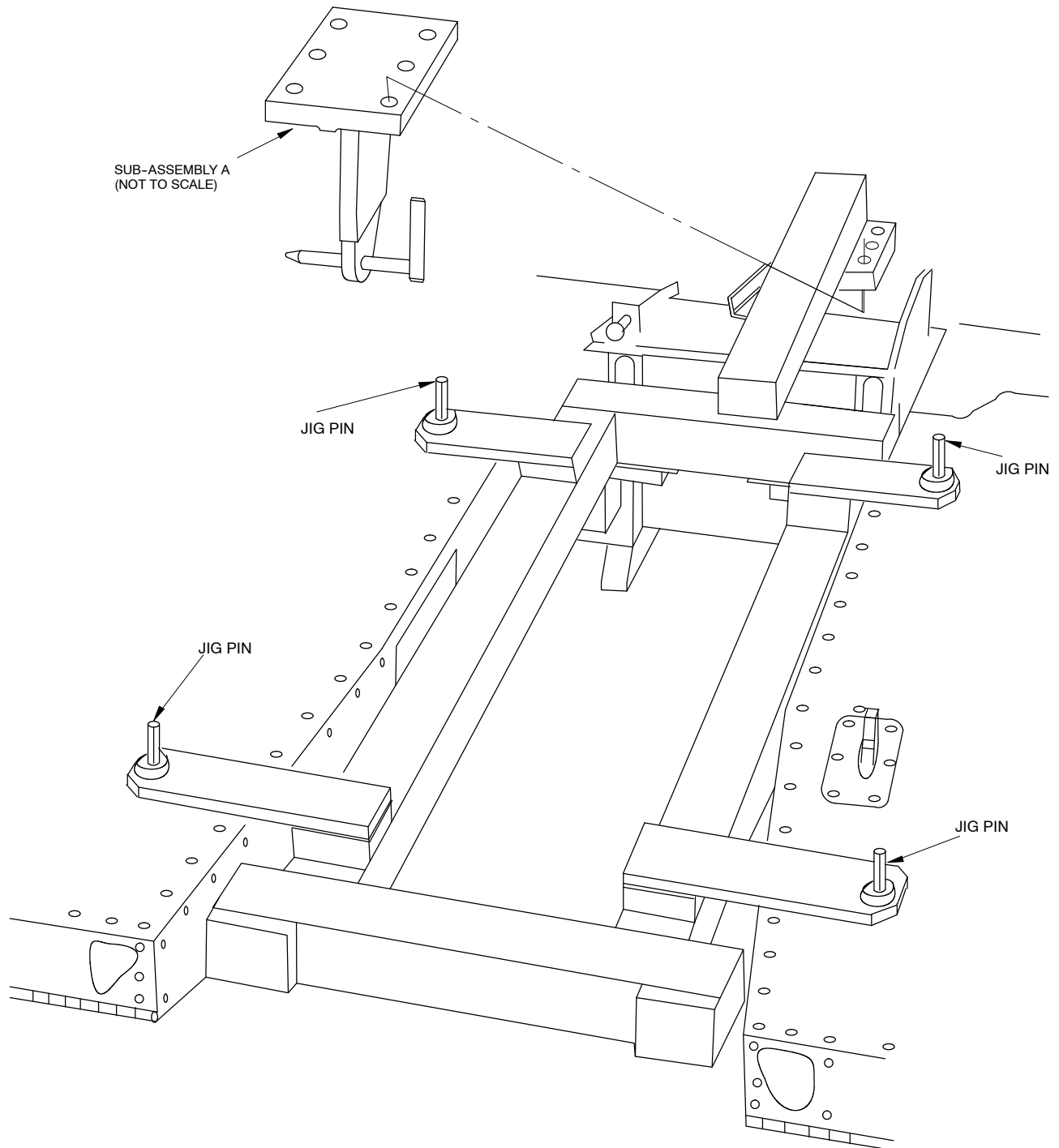

Figure 16 Horizontal Stabiliser Jig

15 Mar 90
Rev 6 1 Jun 92

AEROSPACE TECHNOLOGIES OF AUSTRALIA
A.C.N. 008 622 008
A BOEING AUSTRALIA COMPANY

ANMD-55-26

Page 57

Nomad
ALERT SERVICE BULLETIN

THIS PAGE INTENTIONALLY LEFT BLANK

15 Mar 90

Nomad

ALERT SERVICE BULLETIN

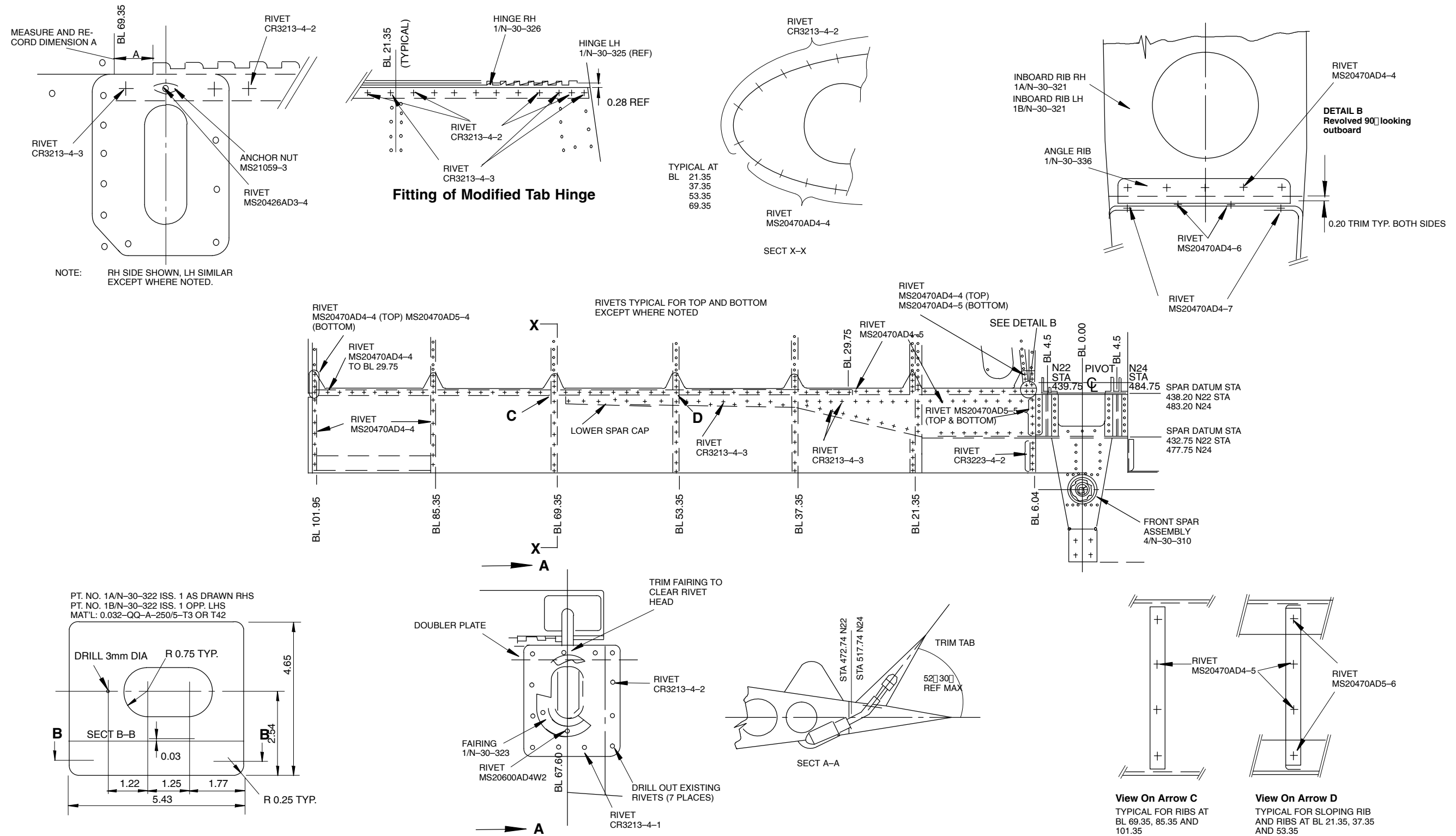

Figure 17 Horizontal Stabiliser — Rework and Fitting of Leading Edge

NMD-55-26

Page 59/(60 blank)

Nomad

ALERT SERVICE BULLETIN

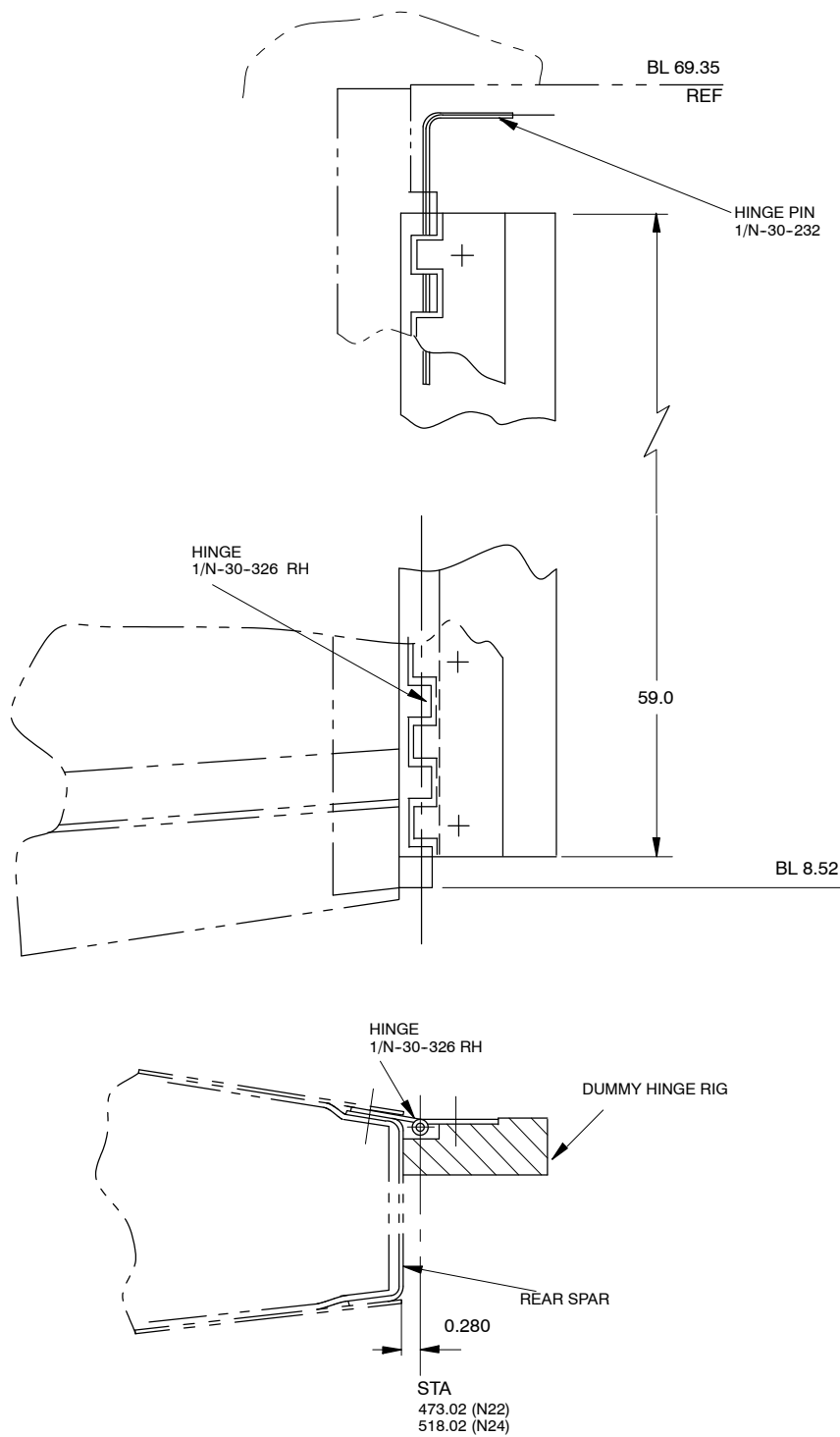

Figure 18 Trim Tab Hinge Installation

15 Mar 90
Rev 6 1 Jun 92

AEROSPACE TECHNOLOGIES OF AUSTRALIA
A.C.N. 008 622 008
A BOEING AUSTRALIA COMPANY

ANMD-55-26

Page 61

Nomad

ALERT SERVICE BULLETIN

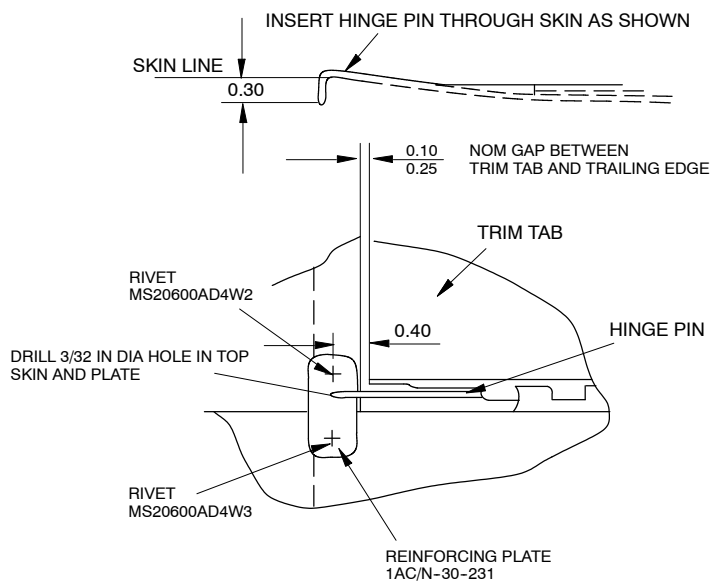
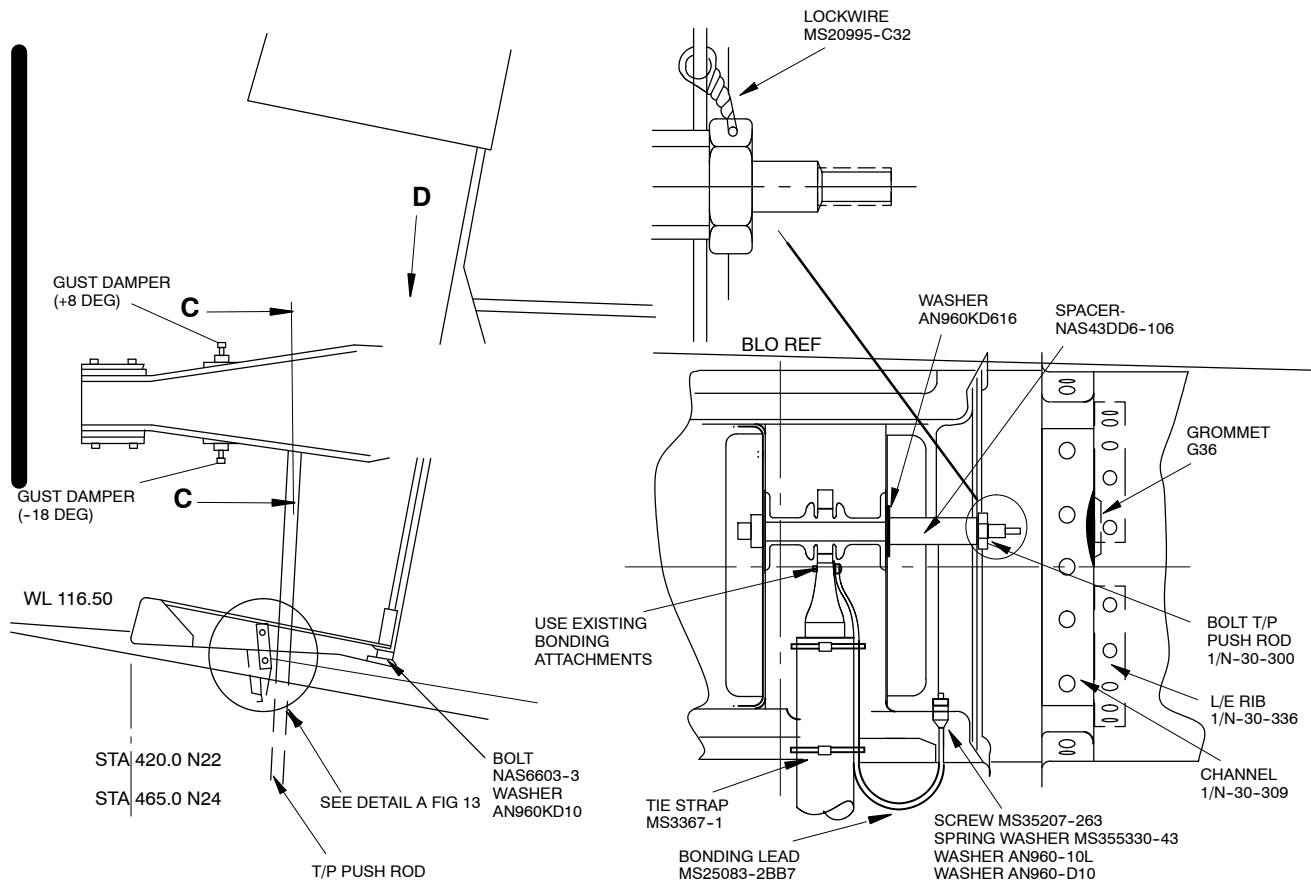

Figure 19 Trim Tab Hinge — Fitting

15 Mar 90
Rev 8 15 Apr 94

Nomad

ALERT SERVICE BULLETIN



SECTION C-C

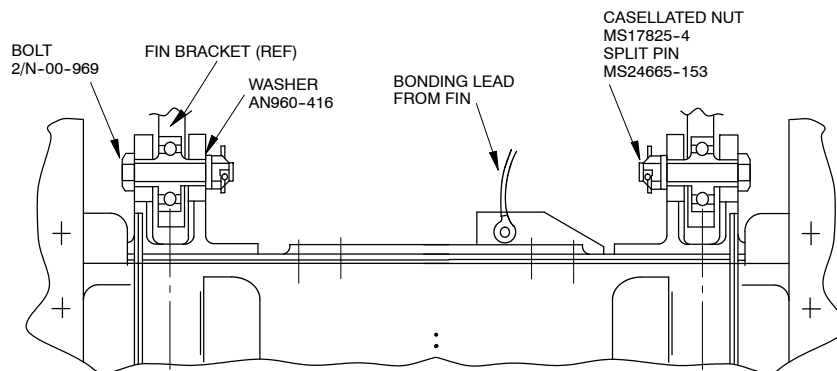

SCRAP VIEW ON ARROW D

Figure 20 Horizontal Stabiliser Installation

15 Mar 90
Rev 8 15 Apr 94

AEROSPACE TECHNOLOGIES OF AUSTRALIA
A.C.N. 008 622 008
A BOEING AUSTRALIA COMPANY

ANMD-55-26

Page 63

Nomad

ALERT SERVICE BULLETIN

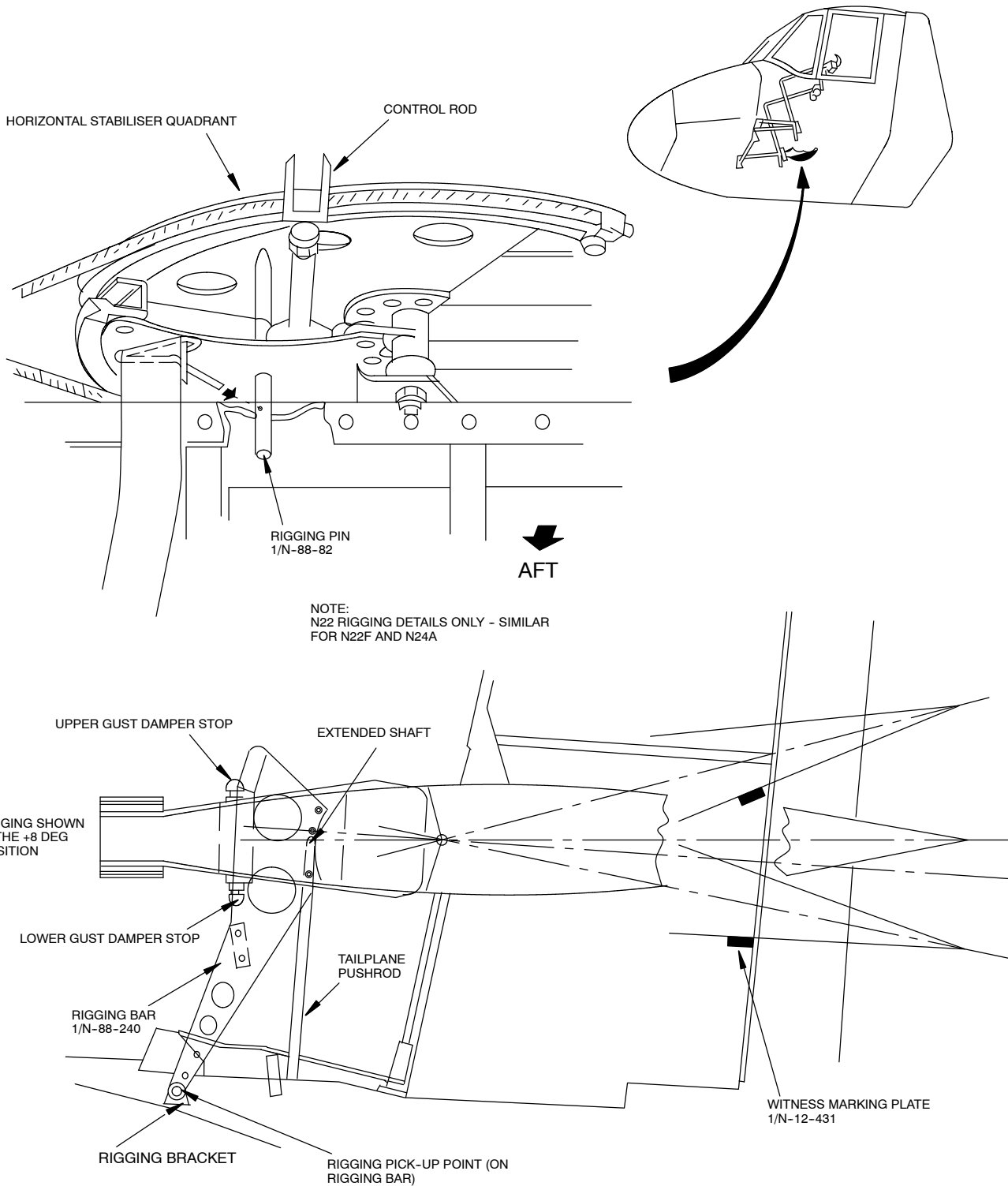

Figure 21 Horizontal Stabiliser — Rigging Details

15 Mar 90
Rev 6 1 Jun 92

AEROSPACE TECHNOLOGIES OF AUSTRALIA
A.C.N. 008 622 008
A BOEING AUSTRALIA COMPANY

ANMD-55-26

Page 64

Nomad

ALERT SERVICE BULLETIN

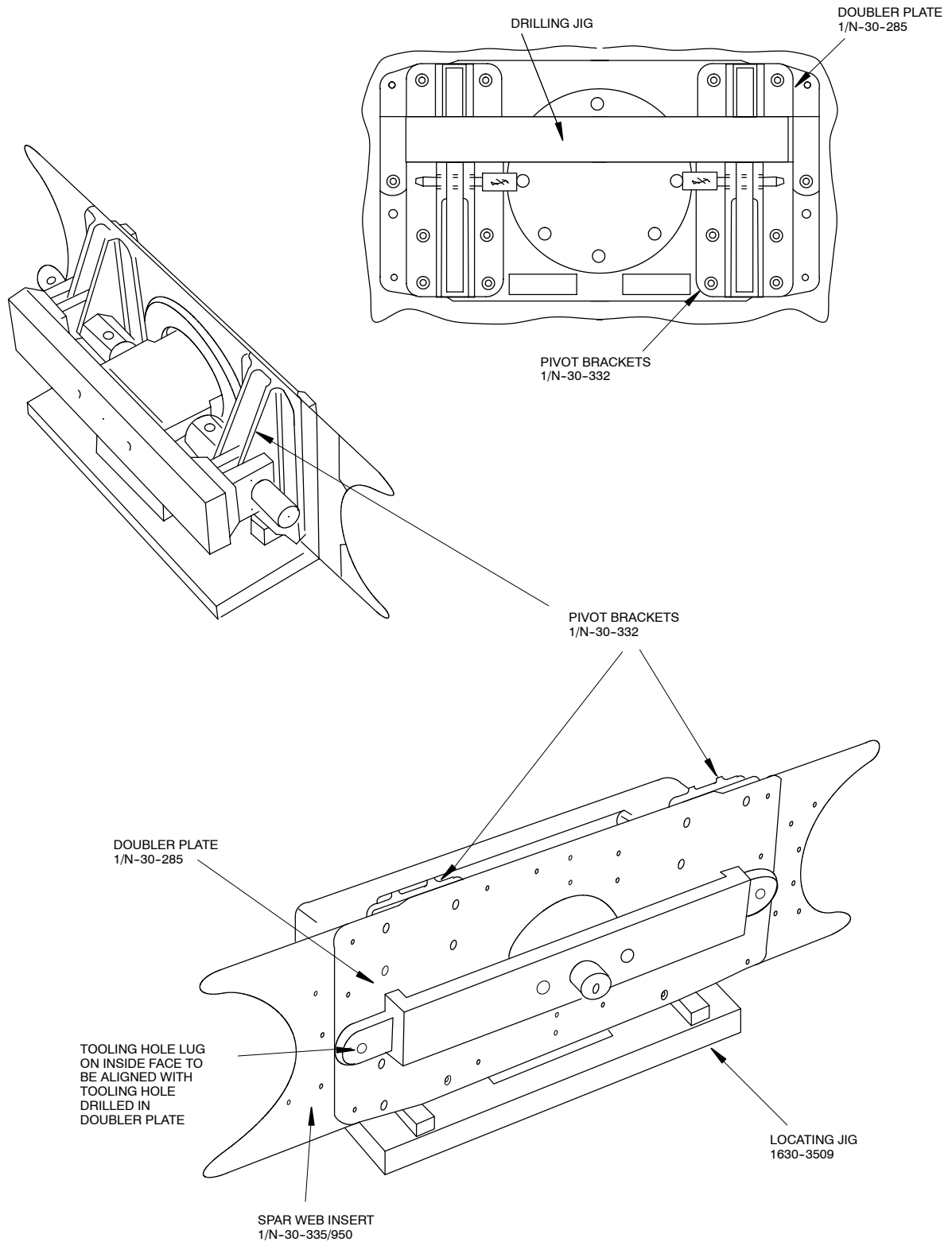

Figure 22 Pivot Bracket Locating Jig — PN 1630-3509

15 Mar 90
Rev 6 1 Jun 92

AEROSPACE TECHNOLOGIES OF AUSTRALIA
A.C.N. 008 622 008
A BOEING AUSTRALIA COMPANY

ANMD-55-26

Page 65

Nomad
ALERT SERVICE BULLETIN

THIS PAGE INTENTIONALLY LEFT BLANK

15 Mar 90

Nomad

ALERT SERVICE BULLETIN

ANNEX A

CERTIFICATE OF INCORPORATION

1. This is to certify that modifications N663 and N768 have been incorporated in accordance with Service Bulletin ANMD-55-26 to the aircraft and horizontal stabilisers as follows:

* ANMD-55-26 Parts 2 and 3 Aircraft S/N _____ Horizontal Stabiliser S/N _____

* ANMD-55-26 Part 3 Spare Horizontal Stabilisers S/N _____ _____ _____
_____ _____ _____
_____ _____ _____

* ANMD-55-26 Part 4 Horizontal Stabiliser S/N _____

*Delete that which is not applicable

Signature _____

Name _____

Company _____

Date _____

2. This is to certify that the old spar PN _____ has been rendered unserviceable by cutting through upper and lower spar caps and webs ten inches or so about the vertical centre line of the spar.

Signature LAME/OIC Maintenance _____