

Service Letter

Subject:

Inspection of wing spars.

Applicability:

All GA200 aircraft

Amendments:

Nil (initial issue).

Background:

An instance of cracking has been reported in the lower section of the front spar cap on GA200 wing, near the wing attachment point. It has been found during the incorporation of optional service bulletin SB-GA200-2011-06 – Wing Spar Life Extension.

Instructions:

The current GA200 Service Manual outlines the GA200 Maintenance Schedules in Chapter 5.

It recommends inspecting for corrosions, disbonds, distortion and damage to spar and internal structures at 100 hourly or annual intervals, whichever comes first.

This Service Letter emphasises the importance of regular and thorough inspection to detect any potential damage, especially in the wing Spar caps region. It is recommended to inspect the Lower Spar Cap area from the fuselage pick-up to the fuel tank.

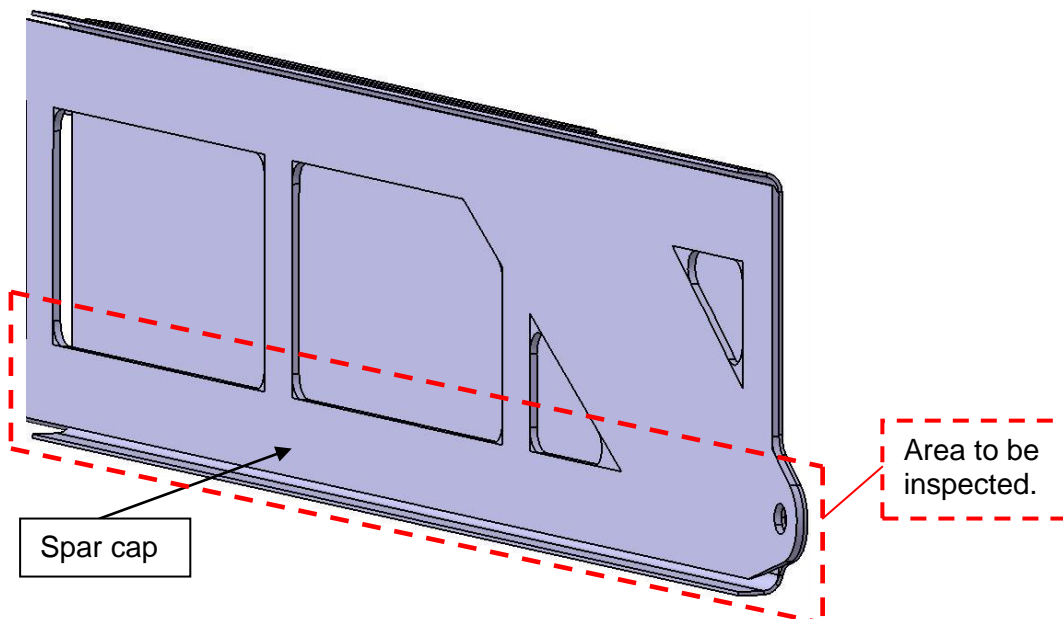



A Mahindra Aerospace Company

SL-GA200-2013-02
Issue 1

PO Box 881, Morwell, Victoria 3840, Australia
Ph + 61 (0) 3 5172 1200
Fax + 61 (0) 3 5172 1201
www.gippsaero.com

Service Letter

If cracks are found, please report to Customer Support Department using contact details below.

Tel.: +61 (0) 3 5172 1200
Fax.: +61 (0) 3 5172 1201
Email: support@gippsaero.com

Should you require any further information please contact our Customer Support Department: