

Service Bulletin

Subject:

Elevator Hinge Upgrade

Applicability:

GA8 serial numbers GA8-04-054 through GA8-07-114, and any GA8 aircraft prior to S/N GA8-04-054 retrofitted with machined hinge brackets by Engineering Release.

Amendments:

Issue 2: Minor corrections and clarifications. Figure 2 added.

Issue 3: Lubrication hole moved 0.125". See Figure 1.

Background:

This Service Bulletin details the modification of the hinge brackets to allow installation of bronze alloy bushes as the wearing medium and for lubrication of the bearing surfaces.

Compliance:

For applicable aircraft, this optional Service Bulletin may be incorporated at the owner's discretion.

Weight and Balance:

Negligible effect.

Approval:

The technical aspects of this Service Bulletin have been approved under a CASA Authorisation.

Parts:

Item	Part Number	Description	Qty
1	GA8-552021-65	OUTBOARD BUSH (INNER)	2
2	GA8-552021-67	CENTRE BUSH (INNER)	2
3	GA8-552021-69	INBOARD BUSH (INNER)	2
4	GA8-552021-165	OUTBOARD BUSH (OUTER)	2
5	GA8-552021-167	BUSH (OUTER)	4

Parts Availability:

New parts can be obtained directly from Gippsland Aeronautics.

Tel.: +61 03 5172 1200

Fax.: +61 03 5172 1201

Email: spares@gippsaero.com

Labour:

Approximately 8 hours should be allocated for completing the upgrade procedure detailed in this Service Bulletin.

Warranty:

Gippsland Aeronautics participation is limited to the supply of parts, including freight, at the owner's expense.

Instructions:**1. Upgrade Procedure**

- 1.1. Remove the elevators from the aircraft in accordance with Section 27-30-00 of the applicable Service Manual.
- 1.2. Carefully ream the elevator pivot holes in the horizontal stabiliser brackets to 0.5625" $\begin{matrix} +0.0005" \\ -0.0000" \end{matrix}$ [14.288 mm $\begin{matrix} +0.013 \\ -0.000 \end{matrix}$ mm]. If a hole is excessively worn it may be difficult to accurately ream the hole centrally. Contact Gippsland Aeronautics if a replacement hinge bracket is required.

CAUTION:

ELEVATOR PIVOT HOLES MUST BE MACHINED ACCURATELY OR EXTENSIVE REPAIRS WILL BE REQUIRED.

- 1.3. Drill lubrication holes of diameter 0.079" \pm 0.005" [2.00 mm \pm 0.13 mm] in the elevator hinge brackets in accordance with figure 1, and countersink at 100° as shown.

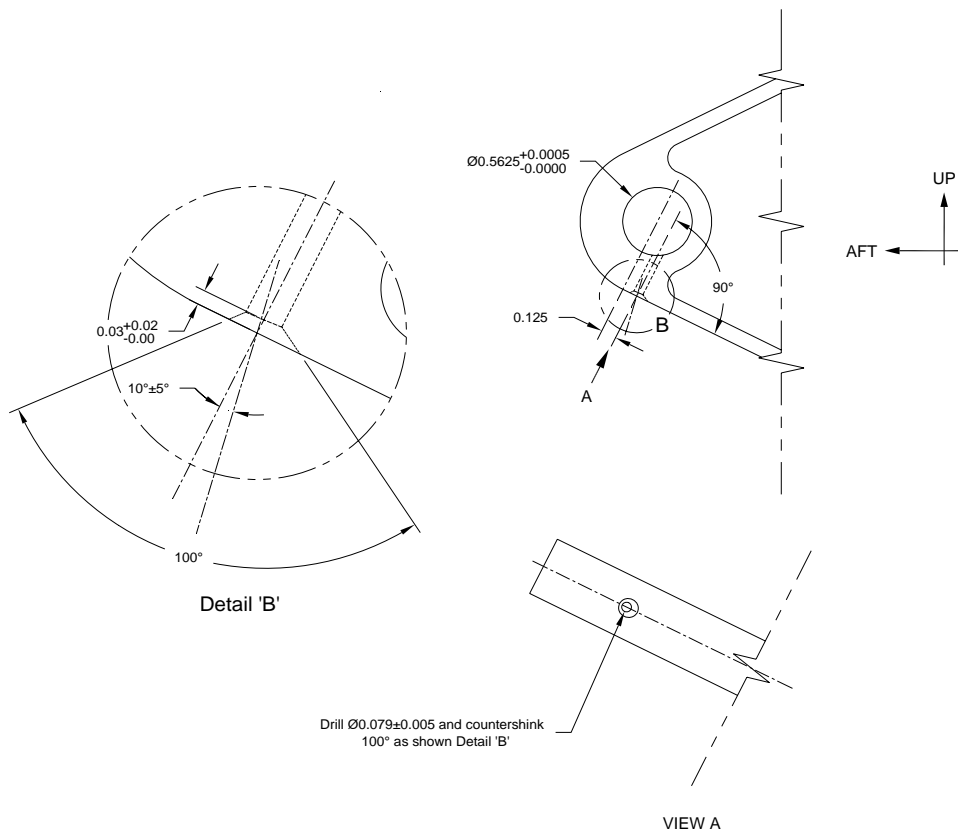
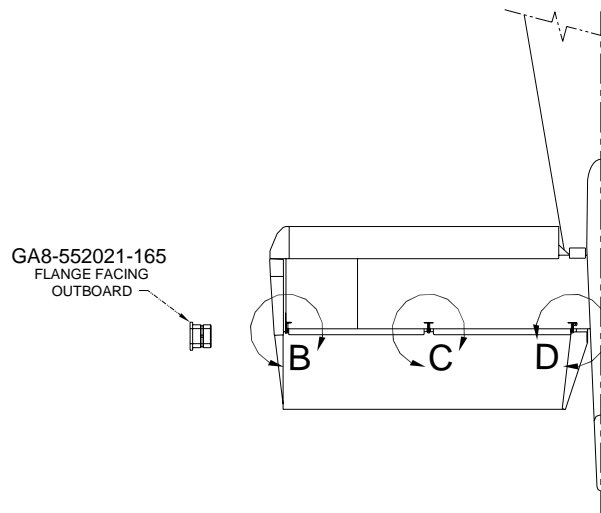

Figure 1

- 1.4. Install the outer bushes (items 4 and 5) with an interference fit in the respective inboard, centre and outboard hinge brackets for each elevator hinge using Loctite 603 (or equivalent), with the flange of each outboard bush located on the outboard face of the respective hinge bracket. The inboard and centre outer bushes are identical. See Figure. 2



ELEVATOR HINGE OUTER BUSH INSTALLATION

SURROUNDING STRUCTURAL DETAIL REMOVED FOR CLARITY.

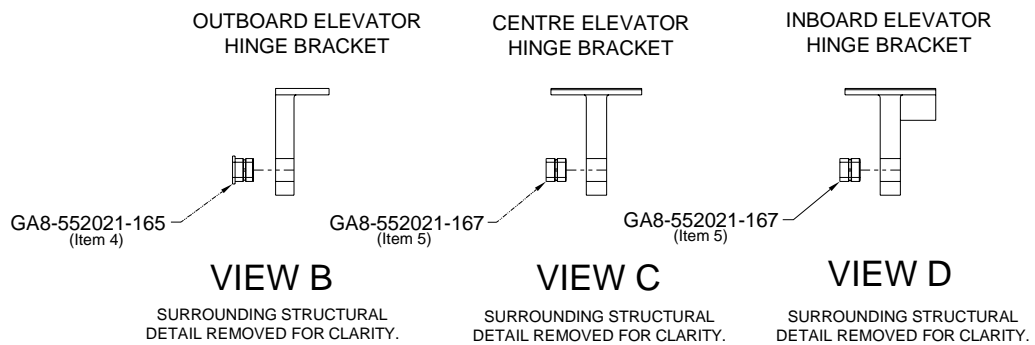

Figure 2

- 1.5. Carefully ream the holes in the installed outer bushes to 0.3750" $\begin{matrix} +0.0005'' \\ -0.0000'' \end{matrix}$ [9.525 mm $\begin{matrix} +0.013 \\ -0.000 \end{matrix}$ mm].
- 1.6. Lubricate replacement inner bushes (items 1, 2 and 3) using general-purpose grease. Install the inner bushes, and reinstall the elevators using original hardware in accordance with Section 27-30-00 of the applicable Service Manual.
- 1.7. Lubricate the hinges using general-purpose grease through the lubrication holes in the brackets.

Documentation:

Update aircraft log book to reflect incorporation of this Service Bulletin.

Compliance Notice:

Complete the Document Compliance Notice and return to Gippsland Aeronautics by fax or mail.

DOCUMENT COMPLIANCE NOTICE



Document: Service Bulletin SB-GA8-200X-XX

Issue X

Aircraft Serial Number: GA8-_____

Service Bulletin SB-GA8-200X-XX Issue X has been incorporated in the above aircraft.

Date: _____

Signed

On behalf of (*company name*): _____

Please post fax or email this compliance notice to:

Gippsland Aeronautics
Attn: Technical Services
P.O. Box 881
Morwell Victoria 3840
Australia
Fax.: +61 03 5172 1201
Email: techrec@gippsaero.com